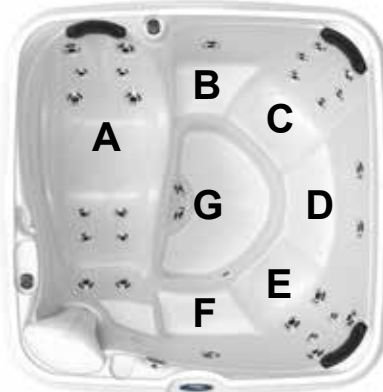

Sundance® Splash™ Berkeley™ 30 Jets

Specifications

Seating Capacity	6 Adults	
Perimeter	312" (792.5 cm)	
Dimensions	78" x 78" x 36" (198 cm x 198 cm x 91 cm);	
Dry Weight	386 lbs (175 kg)	
Filled Weight (Spa Volume)	3,864 lbs (1,753 kg)	
Filled Weight (Average Fill)	2,971 lbs (1,348 kg)	
Water Capacity (Spa Volume)	417 US gallons (1,579 Liters)	
Water Capacity (Average Fill)	310 US gallons (1,173 Liters)	
Electronic Controls	Digital Touch Controller. Offers customizing of cleaning cycles and water temperature setting.	
Pump 1	North America (60 Hz): 2-Speed, 2.0 HPR continuous Export (50 Hz): 2 kW, 2-Speed	
Pump 2	N/A Export (50 Hz): N/A	
Circulation Pump	N/A	
Total Jets	30	
Seat A Jets	6 DirectionalMax1, 6 DirectionalMax2	
Seat B Jets	1 DirectionalMax1	
Seat C Jets	6 DirectionalMax2	
Seat D Jets	2 DirectionalMax1	
Seat E Jets	4 DirectionalMax1, 2 DirectionalMax2	
Seat F Jets	1 DirectionalMax1	
Footwell (G)	2 DirectionalMax1	
Massage Selectors	N/A	
Air Controls	2	
Water Management System	One Easy Kleen 30 ft ² filter cartridge; Optional factory installed Ozone Export (50 Hz): Optional factory installed Ozone	
LED Lighting	Multicolor Waterfall light; Footwell light, Exterior corner lights (8 qty)	
Shell/Cabinet Colors	Mystic Sparkle, Tuscan Sparkle, Night Sparkle, Glacier Sparkle	
Headrests	3	
Waterfalls	One with independent flow rate (on or off) adjustment; powered by pump 1	
Heater:	Hi Flow 1.0kW/4kW Export (50 Hz): Hi Flow 3.0kW	
Electrical Requirements:	North America (60 Hz): Convertible 120 VAC@15A Export (50 Hz): 230-240V@1x16A, 1X32A	
Warranty*	North America (60 Hz): 5 Years Shell, 5 Years Shell Surface, 2 Years Plumbing Component Leaks, 2 Years Equipment and Controls, 5 Years Cabinet, 2 Years Jets, 1 Year Lights; Export (50 Hz): 5 Years Shell, 5 Years Shell Surface, 2 Years Plumbing Component Leaks, 2 Years Equipment and Controls, 2 Years Cabinet, 2 Years Jets, 2 Years Lights;	
Special Features	Optional Suite Package Add-On	

*(See Warranty Document for Specific Details)

Dimensions/Specifications Subject To Change Without Notice

Sundance Splash Berkeley 30 Jets

Operation/Seat Depths

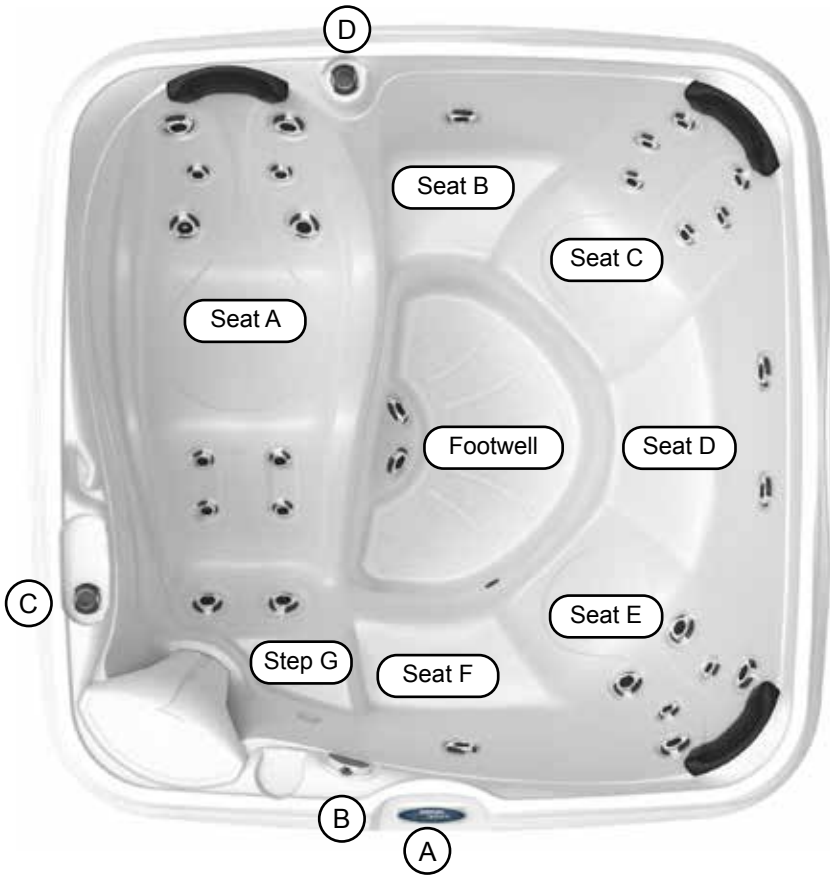

- (A) Topside Control - Activate Jet Pump, Light and Control Water Temperature
 - (B) Water Feature Control - Controls Water Feature Output.
 - (C) Air Control - Activates Seat A Jets (6 DirectionalMax1 Jets, 6 DirectionalMax2 Jets)
 - (D) Air Control - Activates Seat B Jets (1 DirectionalMax1 Jet), Seat C Jets (6 DirectionalMax2 Jets), Seat D Jets (2 DirectionalMax1 Jets), Seat E Jets (4 DirectionalMax1 Jets, 2 DirectionalMax2 Jets), Seat F Jets (1 DirectionalMax1 Jet), Footwell Jets (2 DirectionalMax1 Jets)
- Jet Pump 1: All seats and footwell jets

30 Total Jets

DirectionalMax1
Jets (16)



DirectionalMax2
Jets (14)



Spa Operation Subject To Change Without Notice

SEAT DEPTHS

- A = 25.75" (65.40 cm)
- B = 24.50" (62.23 cm)
- C = 28.00" (71.12 cm)
- D = 24.75" (62.86 cm)
- E = 26.50" (67.30 cm)
- F = 23.25" (59.06 cm)
- G = 19.00" (48.26 cm)
- H = 34.50" (87.63 cm)

Listed dimensions represent distance from top of spa to lowest point in seat.
Tolerance: $\pm 0.5"$ (1.27 cm)



Dimensions/Specifications Subject To Change Without Notice

Sundance Splash Berkeley 30 Jets

Portable Dimensions

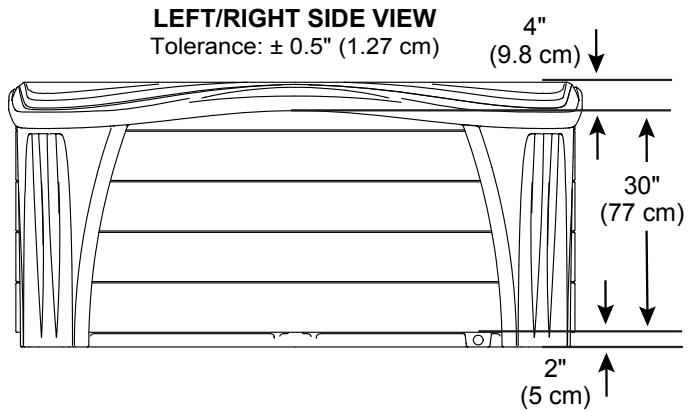
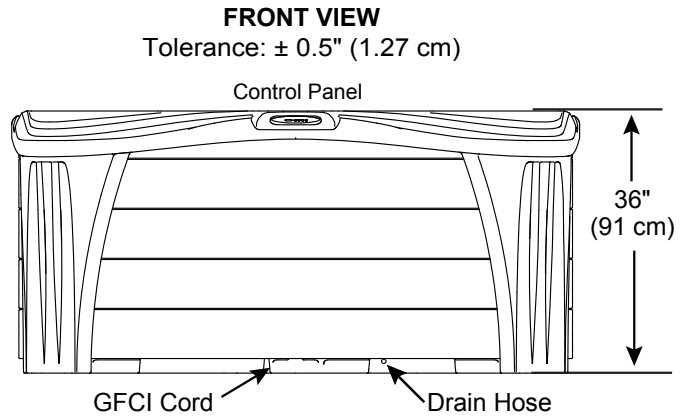
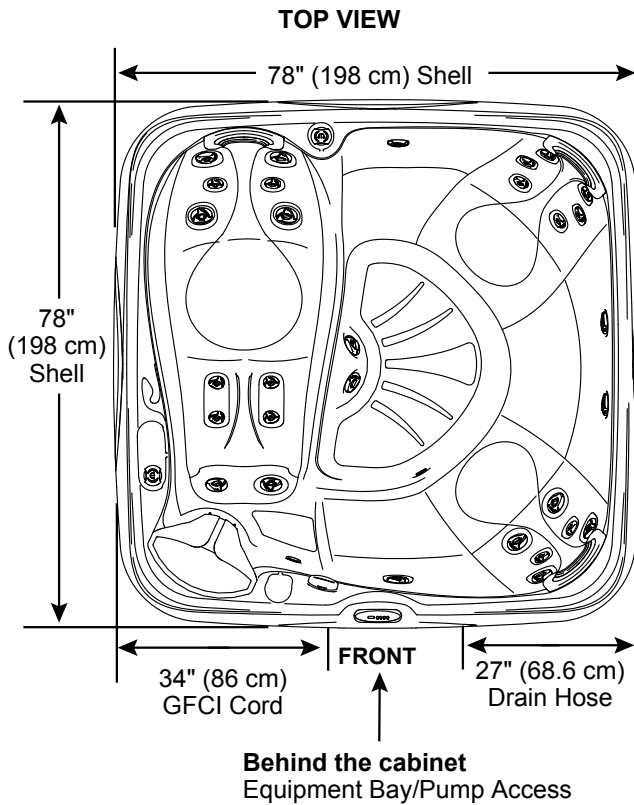

IMPORTANT! Always measure each hot tub for exact dimensions BEFORE designing its foundational support and/or decking.

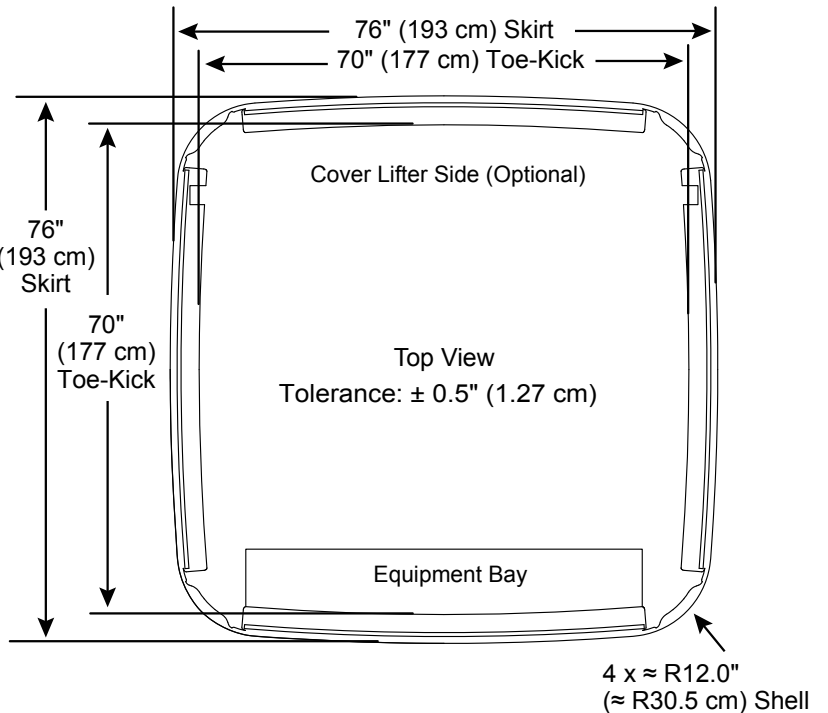

Dimensions/specifications subject to change without notice. Tolerance: $\pm 0.5"$ (1.27 cm)

Dimensions/Specifications Subject To Change Without Notice

Denne modellen kan kobles med 1-fas 230V C-sikring (treg) og 3-fas (400 volt TN-nett - se egne linjer)

Splash-serien:

Berkeley:	For å få mest mulig glede av badet anbefaler vi høyeste kurs for optimal drift.			
	Type varmeelement	Alternativ tilkobling	Funksjon	Kretskortinnstillinger
Berkeley	3 kW	25 amp	Varmeelement og pumper kan brukes samtidig	Se brukermanual.
Berkeley	3 kW	16 amp	Varmeelementet slår seg av når pumpene settes på høy hastighet.	Se brukermanual.