

# Sundance® Splash™ Brook™ 30 Jets

## Specifications

<b>Seating Capacity</b> .....	7 Adults
<b>Perimeter</b> .....	312" (792.5 cm)
<b>Dimensions</b> .....	78" x 78" x 36" (198 cm x 198 cm x 91 cm);
<b>Dry Weight</b> .....	414 lbs (187 kg)
<b>Filled Weight (Spa Volume)</b> .....	4,117 lbs (1,867 kg)
<b>Filled Weight (Average Fill)</b> .....	3,150 lbs (1,429 kg)
<b>Water Capacity (Spa Volume)</b> .....	444 US gallons (1,681 Liters)
<b>Water Capacity (Average Fill)</b> .....	328 US gallons (1,242 Liters)
<b>Electronic Controls</b> .....	Digital Touch Controller. Offers customizing of cleaning cycles and water temperature setting.
<b>Pump 1</b> .....	North America (60 Hz): 2-Speed, 2.0 HP continuous <b>Export (50 Hz): 2 kW, 2-Speed</b>
<b>Pump 2</b> .....	N/A <b>Export (50 Hz): N/A</b>
<b>Circulation Pump</b> .....	N/A
<b>Total Jets</b> .....	30
<b>Seat A Jets</b> .....	4 DirectionalMax1 Jets, 2 DirectionalMax2 Jets
<b>Seat B Jets</b> .....	2 DirectionalMax1 Jets
<b>Seat C Jets</b> .....	8 DirectionalMax2 Jets
<b>Seat D Jets</b> .....	6 DirectionalMax2 Jets
<b>Seat E Jets</b> .....	2 DirectionalMax1 Jets
<b>Seat F Jets</b> .....	4 DirectionalMax1 Jets, 2 DirectionalMax2 Jets
<b>Massage Selectors</b> .....	N/A
<b>Air Controls</b> .....	2
<b>Water Management System</b> .....	One Easy Klean 30 ft <sup>2</sup> filter cartridge; Optional factory installed Ozone <b>Export (50 Hz): Optional factory installed Ozone</b>
<b>LED Lighting</b> .....	Multicolor waterfall light; Exterior corner light (white color only)
<b>Shell/Cabinet Colors</b> .....	Mystic Sparkle, Tuscan Sparkle, Night Sparkle, Glacier Sparkle
<b>Headrests</b> .....	4
<b>Waterfalls</b> .....	One with independent flow rate (on or off) adjustment; powered by pump 1
<b>Heater:</b> .....	Hi Flow 1.0kW/4kW <b>Export (50 Hz): Hi Flow 3.0kW</b>
<b>Electrical Requirements:</b> .....	North America (60 Hz): Convertible 120 VAC@15A <b>Export (50 Hz): 230-240V@1x16A, 1X32A</b>
<b>Warranty*</b> .....	North America (60 Hz): 5 Years Shell, 5 Years Shell Surface, 2 Years Plumbing Component Leaks, 2 Years Equipment and Controls, 5 Years Cabinet, 2 Years Jets, 1 Year Lights; <b>Export (50 Hz): 5 Years Shell, 5 Years Shell Surface, 2 Years Plumbing Component Leaks, 2 Years Equipment and Controls, 2 Years Cabinet, 2 Years Jets, 2 Years Lights;</b>
<b>Special Features</b> .....	N/A



\*(See Warranty Document for Specific Details)

Dimensions/Specifications Subject To Change Without Notice

# Sundance Splash Brook 30 Jets

## Operation/Seat Depths



- (A) Topside Control - Activate Jet Pump, Light and Control Water Temperature
  - (B) Water Feature Control - Controls Water Feature Output.
  - (C) Air Control - Activates Seat A Jets (4 DirectionalMax1 Jets, 2 DirectionalMax2 Jets), Seat B Jets (2 DirectionalMax1 Jets), Seat C Jets (8 DirectionalMax2 Jets)
  - (D) Air Control - Activates Seat D Jets (6 DirectionalMax2 Jets), Seat E Jets (2 DirectionalMax1 Jets), Seat F Jets (4 DirectionalMax1 Jets, 2 DirectionalMax2 Jets)
- Jet Pump 1: All seats and footwell jets

### 30 Total Jets

DirectionalMax1  
Jets (12)

DirectionalMax2  
Jets (18)



Spa Operation Subject To Change Without Notice

## SEAT DEPTHS

- A = 26.50" (67.30 cm)
- B = 24.75" (62.86 cm)
- C = 28.00" (71.12 cm)
- D = 28.00" (71.12 cm)
- E = 24.75" (62.86 cm)
- F = 26.50" (67.30 cm)
- G = 20.00" (50.80 cm)
- H = 34.50" (87.63 cm)

Listed dimensions represent distance from top of spa to lowest point in seat.  
Tolerance: ± 0.5" (1.27 cm)



Dimensions/Specifications Subject To Change Without Notice

# Sundance Splash Brook 30 Jets

## Portable Dimensions

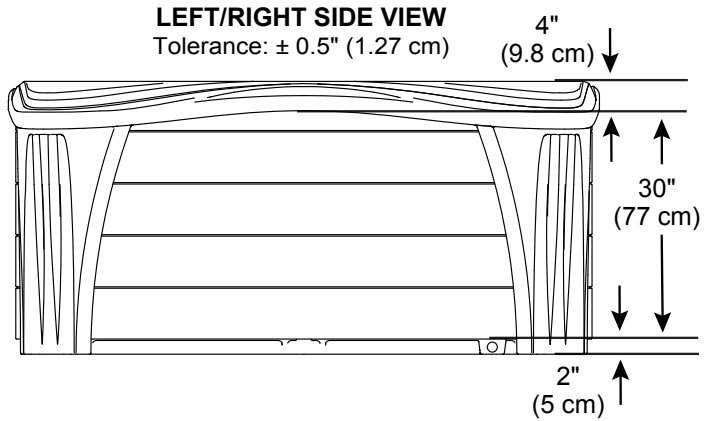
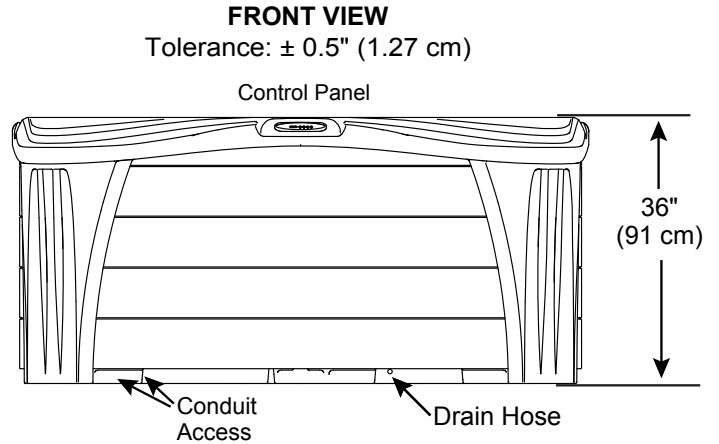
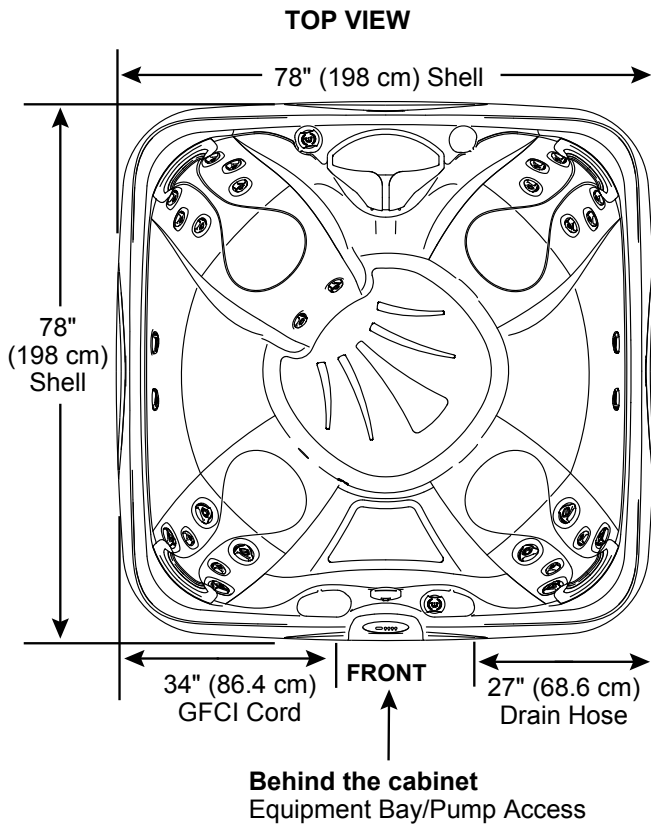

**IMPORTANT! Always measure each hot tub for exact dimensions BEFORE designing its foundational support and/or decking.**

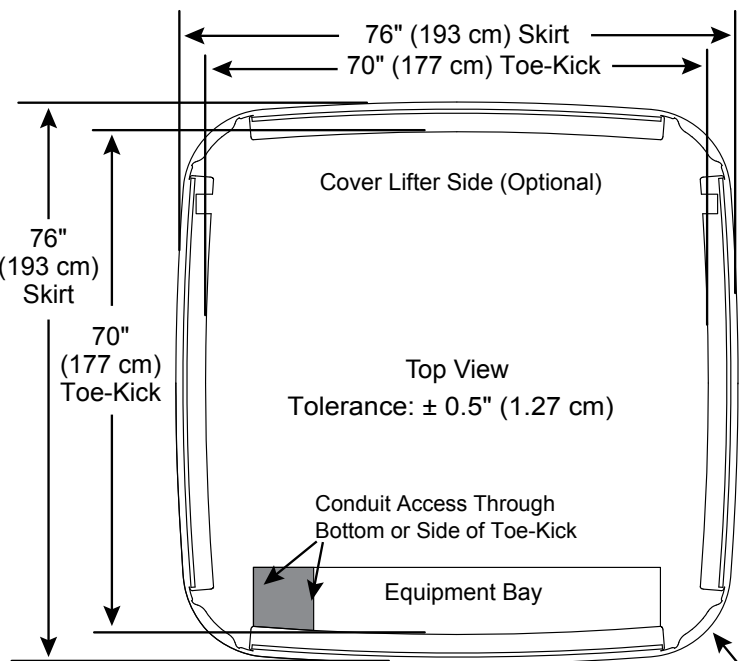

Dimensions/specifications subject to change without notice. Tolerance:  $\pm 0.5"$  (1.27 cm)

4 x  $\approx R12.0"$   
( $\approx R30.5$  cm) Shell

Denne modellen kan kobles med 1-fas 230V C-sikring (treg) og 3-fas (400 volt TN-nett - se egne linjer)

**Splash-serien:**

<b>Brook:</b>	For å få mest mulig glede av badet anbefaler vi høyeste kurs for optimal drift.			
	<b>Type varmeelement</b>	<b>Alternativ tilkobling</b>	<b>Funksjon</b>	<b>Kretskortinnstillinger</b>
Brook	3 kW	25 amp	Varmeelement og pumper kan brukes samtidig	Se brukermanual.
Brook	3 kW	16 amp	Varmeelementet slår seg av når pumpene settes på høy hastighet.	Se brukermanual.